

HAWK PAN Fire Board Partition System

1-hour fire Rated Partition Hawk Pan (9mm)

- ① One layer of 9mm thick HAWK PAN (fire rated board)
- ② Rock wool 50mm x 80kg/m³
- ③ 50mm x 50mm x 0.6mm thick Galvanized Steel U Channel at nominal 610mm
- ④ 50mm x 38mm x 0.6mm thick Galvanized Steel C Channel
- ⑤ Self-tapping screws M3.5 at nominal 250mm centres
- ⑥ M6 Anchor bolts at nominal 500mm centres
- ⑦ Firestop Acrylic Sealant

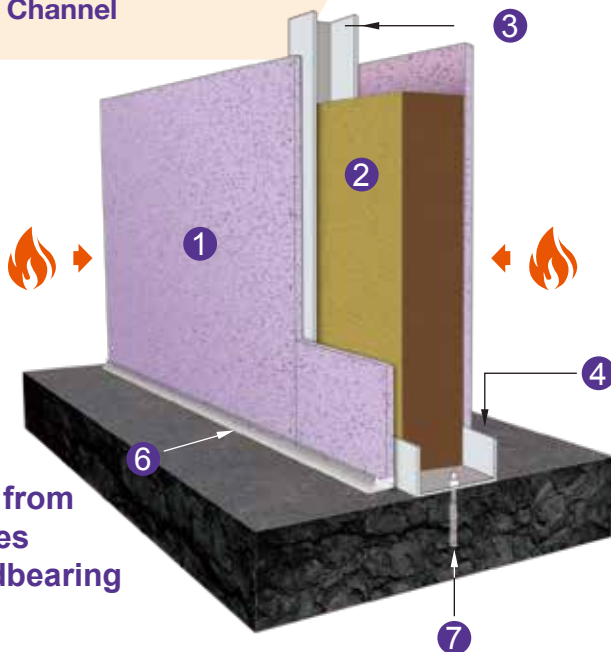
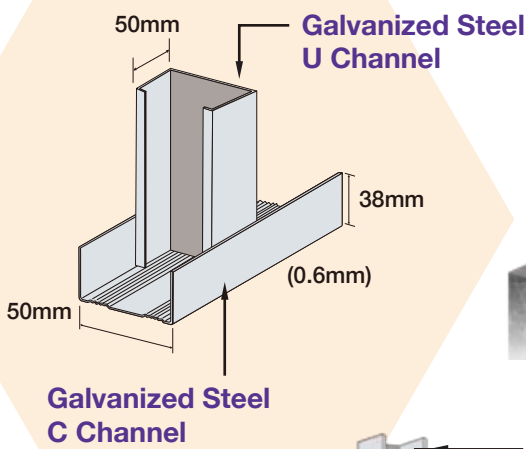
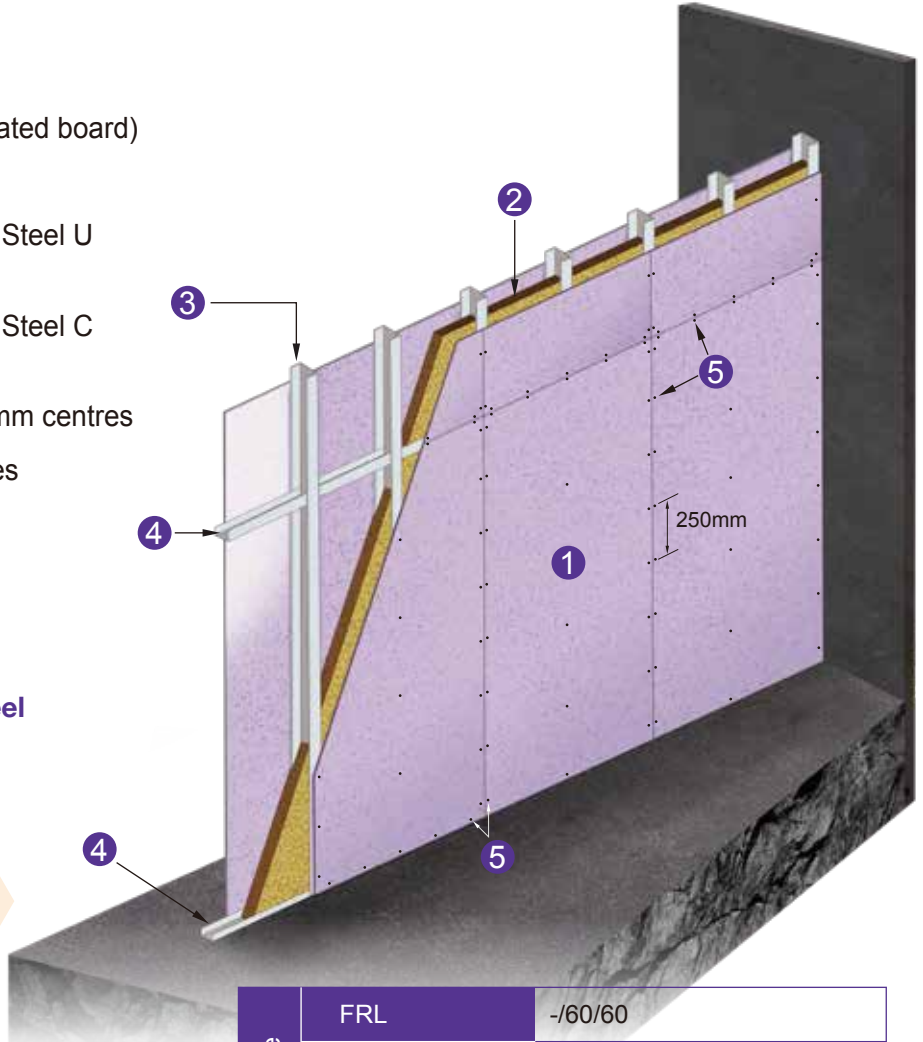

Fire resistance	FRL	-/60/60
	Standard	BS EN 1364 - 1: 1999 BS 476: Part 20: 1987 BS 476: Part 22: 1987
	Approval	IA 15-029 FORTE
Acoustic	Standard #STC	ASTM E90-09, ASTM E413-10 45
	Standard #RW	ISO140: Part 1&3: 1996 48 DB
	Predicted assessment	(A + A)*L 20 th August 2015
Construction	Maximum height	6000mm
	Partition length	Unlimited
	Partition thickness	68mm
	Partition mass	31kg/m ²

**Fire risk from
both sides
Non loadbearing
partition**